

2.8

Namur Valves

Namur 1/4" also called "Namur 1" in accordance to VDI/VDE 3845. Namur 1/2" also called "Namur 2".

Selected models are available for explosion hazardous environment. They are ATEX-Ex certified. For detailed information refer to chapter 2.12.

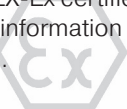

Selected models are available for low temperature application. Temperature-range: - 50° C to + 50° C. For detailed information refer to chapter 2.9.



Selected models are available in stainless steel. For detailed information refer to chapter 2.10.

MNH 310 701/MNH 310 711/MNH 311 701 MNOH 310 701/MNK 310 701/MNK 311 701

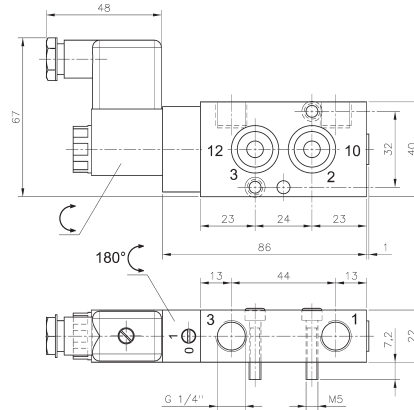
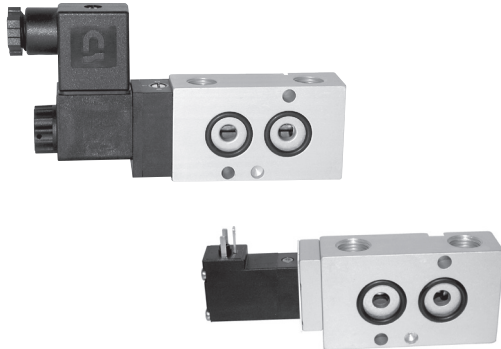
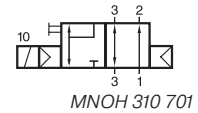
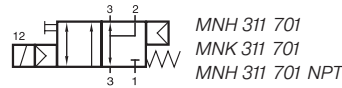
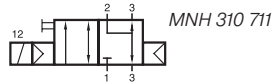
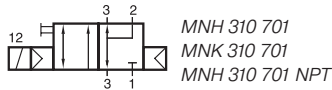

**MNH 310 701/MNH 311 701/MNOH 310 701
MNH 310 701 NPT/MNH 311 701 NPT**

3/2-way solenoid valve, actuated by permanent signal. Interface according to 1/4" Namur standard, with exhaust air recirculation ("purge").

Type MNH 31_7_1 normally closed
Type MNOH 31_701 normally open
Type MNK 31_701 n.c. low power

MNH 310 701, MNH 310 711, MNOH 310 701 and MNK 310 701 with pneumatic spring return, MNH 311 701 and MNK 311 701 with combined spring assuring a fail-safe function.

MNH generally with manual override to turn with actuators 230V/50Hz, 110V/50Hz, 24V/50Hz, 48V=, 24V=, 12V=.

Delivery includes 1 pin, 2 screws, 2 O-rings and 1 connector.

MNK with manual override to push with actuators 230V/50Hz, 110V/50Hz, 24V/50Hz, 24V=, 12V=, 6V=

Delivery includes 1 pin, 2 screws and 2 O-rings.

Selected products displayed on this page are also available NPT threaded.

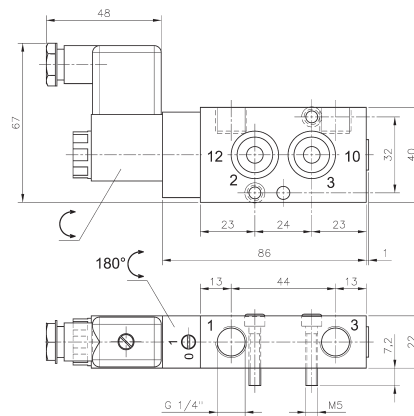

MNH 310 711 ports 1 and 3 are swapped!

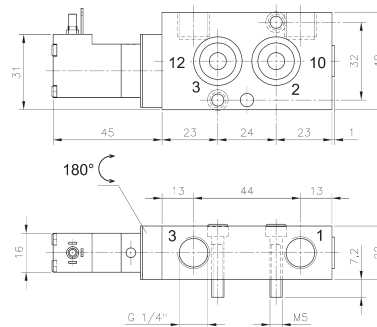

MNK 310 701/MNK 311 701

Type	Function	Port size	Air flow	Operating press.	Power cons.	Weight
MNH 310 701	n.c.	G 1/4"	1250 l/min	2 - 10 bar	3 W = / 5 VA ~	0,26 kg
MNOH 310 701	n.o.	G 1/4"	1250 l/min	2 - 10 bar	3 W = / 5 VA ~	0,26 kg
MNH 310 711	n.c.	G 1/4"	1250 l/min	2 - 10 bar	3 W = / 5 VA ~	0,26 kg
MNH 311 701	n.c.	G 1/4"	1250 l/min	2,5 - 10 bar	3 W = / 5 VA ~	0,26 kg
MNK 310 701	n.c.	G 1/4"	1250 l/min	2 - 10 bar	1,8 W = / 3 VA ~	0,21 kg
MNK 311 701	n.c.	G 1/4"	1250 l/min	2,5 - 10 bar	1,8 W = / 3 VA ~	0,21 kg
MNH 310 701 NPT	n.c.	1/4" NPT	1250 l/min	2 - 10 bar	3 W = / 5 VA ~	0,26 kg
MNH 311 701 NPT	n.c.	1/4" NPT	1250 l/min	2,5 - 10 bar	3 W = / 5 VA ~	0,26 kg



MNH 310 101/MNH 311 101 MNH 310 121/MNH 311 121

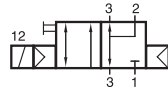

MNH 310 101
MNH 310 121
MNH 310 121 NPT

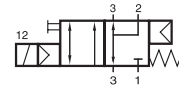

MNH 311 101
MNH 311 121
MNH 311 121 NPT

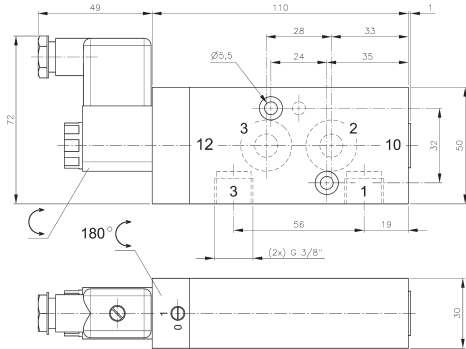

MNH 310 101/MNH 311 101

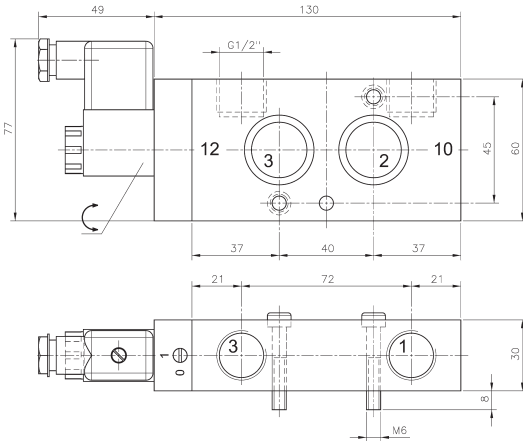

**MNH 310 121/MNH 311 121
MNH 310 121 NPT/MNH 311 121 NPT**

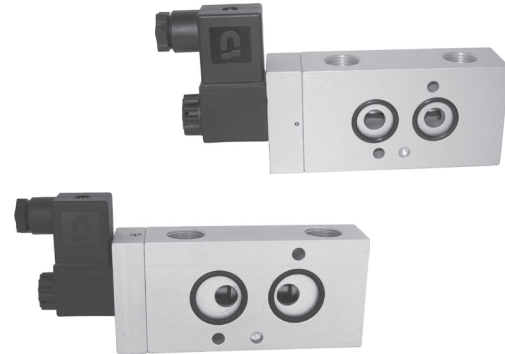

3/2-way solenoid valve, actuated by permanent signal. Interface according to Namur standard, with exhaust air recirculation ("purge").

Type 101 according to 1/4" Namur standard
Type 121 according to 1/2" Namur standard

MNH 310 101, MNH 310 121 with pneumatic spring return, MNH 311 101 and MNH 311 121 with combined spring assuring a fail-safe function.

Available with actuators:
230V/50Hz, 110V/50Hz, 24V/50Hz, 48V=,
24V=, 12V=.

The valves are generally equipped with manual override to turn.

Delivery includes 1 pin, 2 screws, 2 O-rings and 1 connector.

Selected products displayed on this page are also available NPT threaded..

Type	Namur	Port size	Air flow	Operating press.	Power cons.	Weight
MNH 310 101	1/4"	G 3/8"	2250 l/min	1,5 - 10 bar	3 W = / 5 VA ~	0,55 kg
MNH 311 101	1/4"	G 3/8"	2250 l/min	2,5 - 10 bar	3 W = / 5 VA ~	0,55 kg
MNH 310 121	1/2"	G 1/2"	3000 l/min	1,0 - 10 bar	3 W = / 5 VA ~	0,70 kg 
MNH 311 121	1/2"	G 1/2"	3000 l/min	2,5 - 10 bar	3 W = / 5 VA ~	0,70 kg
MNH 310 121 NPT	1/2"	1/2" NPT	3000 l/min	1,0 - 10 bar	3 W = / 5 VA ~	0,70 kg
MNH 311 121 NPT	1/2"	1/2" NPT	3000 l/min	2,5 - 10 bar	3 W = / 5 VA ~	0,70 kg

MNH 510 701/MNH 510 711/MNH 511 701 MNH 511 711/MNK 510 701/MNK 511 701

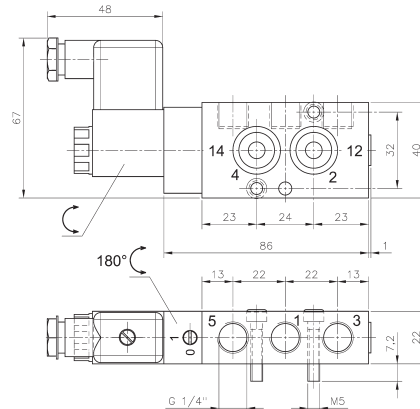
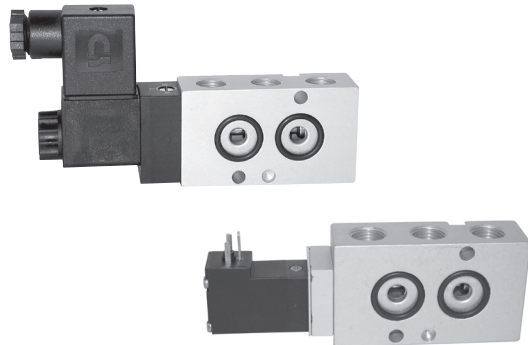
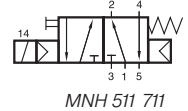
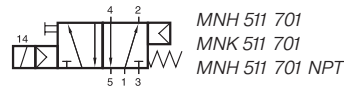
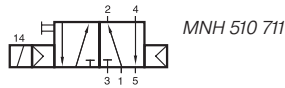
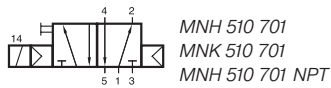

MNH 510 701/MNH 511 701
MNH 510 701 NPT/MNH 511 701 NPT

5/2-way solenoid valve, actuated by permanent signal. Interface according to 1/4" Namur standard.

MNH 510 701, MNH 510 711 and MNK 510 701 with pneumatic spring return, MNH 511 701, MNH 511 711 and MNK 511 701 with combined spring.

MNH generally with manual override to turn with actuators 230V/50Hz, 110V/50Hz, 24V/50Hz, 48V=, 24V=, 12V=.

Delivery includes 1 pin, 2 screws, 2 O-rings and 1 connector.

MNK with manual override to push with actuators 230V/50Hz, 110V/50Hz, 24V/50Hz, 24V=, 12V=, 6V=.

Delivery includes 1 pin, 2 screws and 2 O-rings.

Selected products displayed on this page are also available NPT threaded.

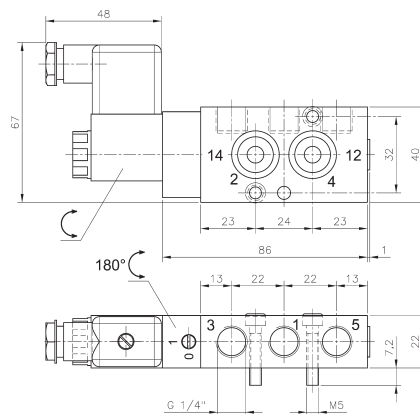

MNH 510 711/MNH 511 711
ports 2,4,3,5 are swapped!

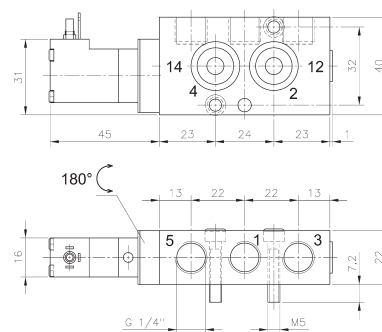

MNK 510 701/MNK 511 701

Type	Port size	Air flow	Operating press.	Power consumption	Weight
MNH 510 701	G 1/4"	1250 l/min	2 - 10 bar	3 W = / 5 VA ~	0,26 kg
MNH 510 711	G 1/4"	1250 l/min	2 - 10 bar	3 W = / 5 VA ~	0,26 kg
MNH 511 701	G 1/4"	1250 l/min	2,5 - 10 bar	3 W = / 5 VA ~	0,26 kg
MNH 511 711	G 1/4"	1250 l/min	2,5 - 10 bar	3 W = / 5 VA ~	0,26 kg
MNK 510 701	G 1/4"	1250 l/min	2 - 10 bar	1,8 W = / 3 VA ~	0,21 kg
MNK 511 701	G 1/4"	1250 l/min	2,5 - 10 bar	1,8 W = / 3 VA ~	0,21 kg
MNH 510 701 NPT	1/4" NPT	1250 l/min	2 - 10 bar	3 W = / 5 VA ~	0,26 kg
MNH 511 701 NPT	1/4" NPT	1250 l/min	2,5 - 10 bar	3 W = / 5 VA ~	0,26 kg



MNH 510 101/MNH 511 101 MNH 510 121/MNH 511 121

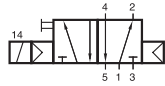

MNH 510 101
MNH 510 121
MNH 510 121 NPT

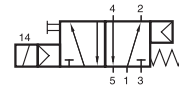

MNH 511 101
MNH 511 121
MNH 511 121 NPT

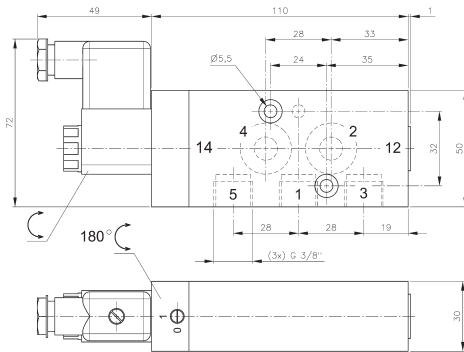

MNH 510 101/MNH 511 101

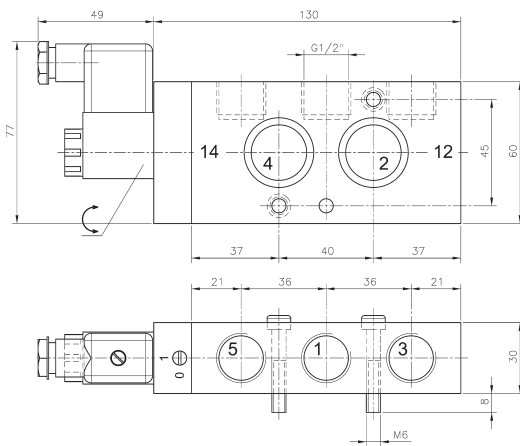

**MNH 510 121/MNH 511 121
MNH 510 121 NPT/MNH 511 121 NPT**

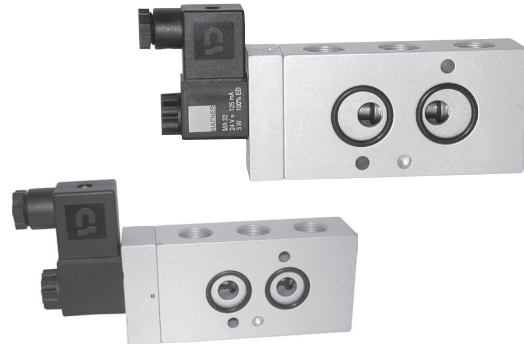

5/2-way solenoid valve, actuated by permanent signal. Interface according to Namur standard.

Type 101 according to 1/4" Namur standard
Type 121 according to 1/2" Namur standard

MNH 510 101, MNH 510 121 with pneumatic spring return, MNH 511 101 and MNH 511 121 with combined spring.

Available with actuators:
230V/50Hz, 110V/50Hz, 24V/50Hz, 48V=,
24V=, 12V=.

The valves are generally equipped with manual override to turn.

Delivery includes 1 pin, 2 screws, 2 O-rings and 1 connector.

Selected products displayed on this page are also available NPT threaded.

Type	Namur	Port size	Air flow	Operating press.	Power cons.	Weight
MNH 510 101	1/4"	G 3/8"	2250 l/min	1,5 - 10 bar	3 W = / 5 VA ~	0,55 kg
MNH 511 101	1/4"	G 3/8"	2250 l/min	2,5 - 10 bar	3 W = / 5 VA ~	0,55 kg
MNH 510 121	1/2"	G 1/2"	3000 l/min	1,0 - 10 bar	3 W = / 5 VA ~	0,70 kg 
MNH 511 121	1/2"	G 1/2"	3000 l/min	2,5 - 10 bar	3 W = / 5 VA ~	0,70 kg
MNH 510 121 NPT	1/2"	1/2" NPT	3000 l/min	1,0 - 10 bar	3 W = / 5 VA ~	0,70 kg
MNH 511 121 NPT	1/2"	1/2" NPT	3000 l/min	2,5 - 10 bar	3 W = / 5 VA ~	0,70 kg

MNH 520 701/MNH 520 101/MNH 520 121 MNK 520 701

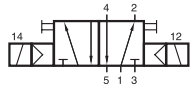

MNH 520 701
MNH 520 101
MNH 520 121
MNK 520 701
MNH 520 701 NPT
MNH 520 121 NPT

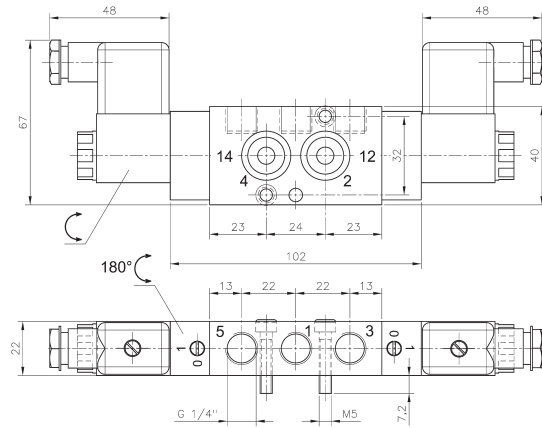
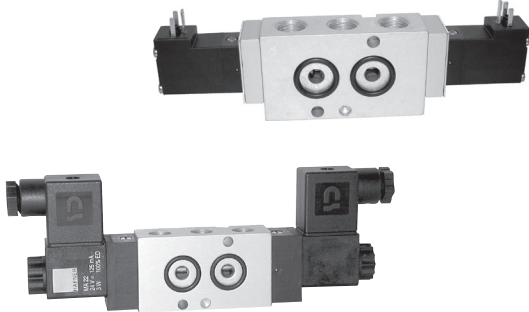

MNH 520 701/MNH 520 701 NPT

5/2-way solenoid valve actuated by impulse. Position is kept until next electrical signal even when not attached to electrical source. Interface according to Namur standard.

MNH generally with manual override to turn with actuators 230V/50Hz, 110V/50Hz, 24V/50Hz, 48V=, 24V=, 12V=.
Delivery includes 1 pin, 2 screws, 2 O-rings and 1 connector.

MNK with manual override to push with actuators 230V/50Hz, 110V/50Hz, 24V/50Hz, 24V=, 12V=, 6V=.
Delivery includes 1 pin, 2 screws and 2 O-rings.

Selected products displayed on this page are also available NPT threaded.

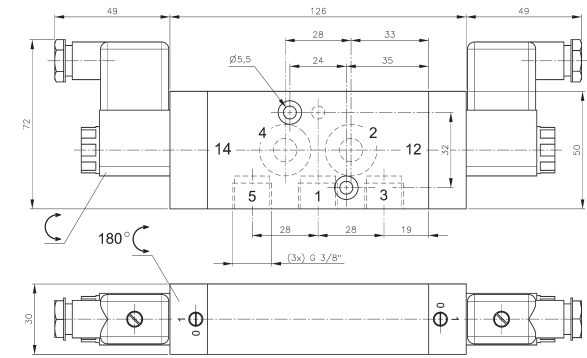

MNH 520 101

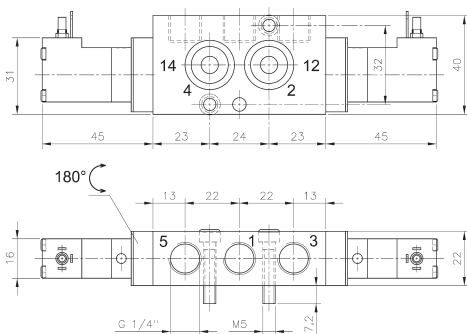

MNK 520 701

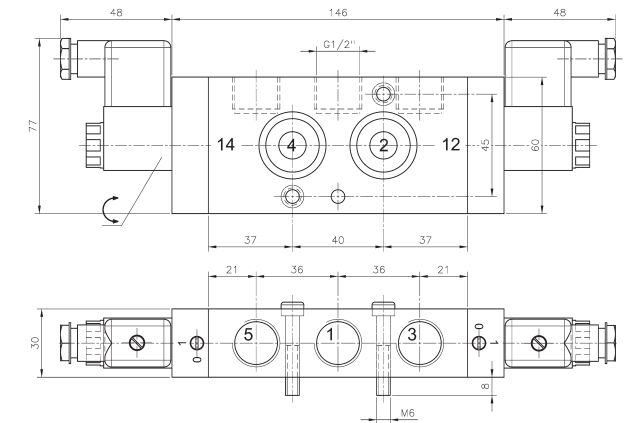

MNH 520 121/MNH 520 121 NPT

Type	Namur	Port size	Air flow	Operating press.	Power cons.	Weight
MNH 520 701	1/4"	G 1/4"	1250 l/min	2 - 10 bar	3 W = / 5 VA ~	0,35 kg
MNH 520 101	1/4"	G 3/8"	2250 l/min	1,5 - 10 bar	3 W = / 5 VA ~	0,84 kg
MNH 520 121	1/2"	G 1/2"	3000 l/min	1,0 - 10 bar	3 W = / 5 VA ~	0,87 kg
MNK 520 701	1/4"	G 1/4"	1250 l/min	2 - 10 bar	1,8 W = / 3 VA ~	0,31 kg
MNH 520 701 NPT	1/4"	1/4" NPT	1250 l/min	1,5 - 10 bar	3 W = / 5 VA ~	0,35 kg
MNH 520 121 NPT	1/2"	1/2" NPT	3000 l/min	1,0 - 10 bar	3 W = / 5 VA ~	0,87 kg

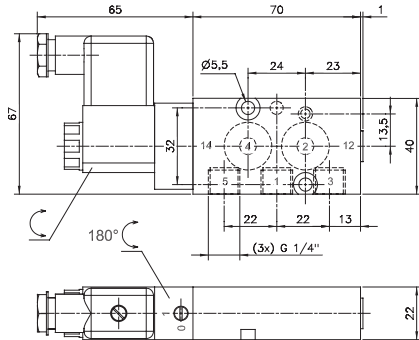
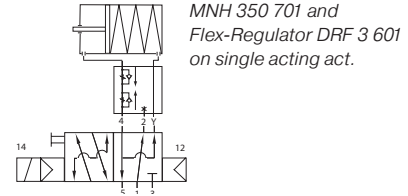
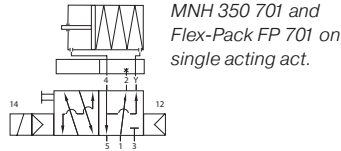
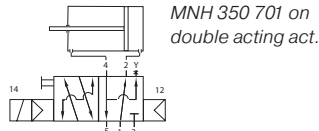

MNH 350 701/MNH 351 701

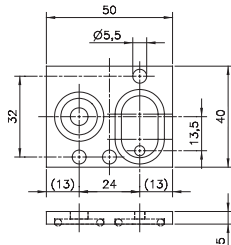

FP 701 K/FP 701 A

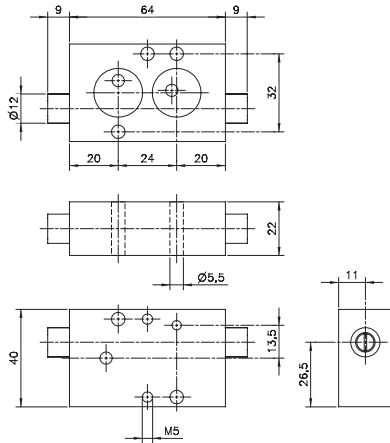

DRF 3 601

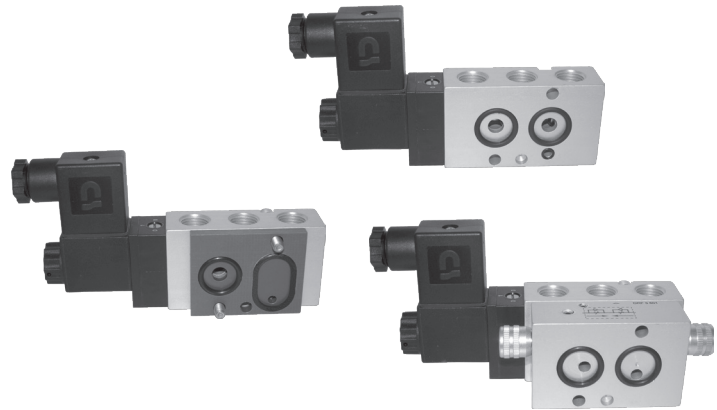

5/2-way solenoid valve, actuated by permanent signal. Interface according to 1/4" Namur standard. Adding the „Flex-Pack“, converts the valve into a 3/2-way-Namurvalve with exhaust-air recirculation (“purge”).

MNH 350 701 with pneumatic spring return, MNH 351 701 with combined spring.

Valves are available with solenoid operators: 230V/50Hz, 110V/50Hz, 24V/50Hz, 48V=, 24V-, 12V=

Valves are generally equipped with manual override.

Delivery of valve includes 1 pin, 2 screws, 2 O-rings and 1 connector.

Instead of the Flex-Pack the „Flex-regulator“ Type DRF 601 converts the function of the valve and offers the possibility to control opening- and closing-speed of a spring-return actuator independently.

Delivery of FP 701 and DRF 3 601 includes longer screws, seals as well as a plug to close port 3 of the valve.

Type	Material	Orifice 4	Orifice 2-3	Weight
FP 701 K	PA	7 mm	4 mm	0,012 kg
FP 701 A	alu	7 mm	4 mm	0,016 kg
DRF 3 601	alu + brass	0,5 - 6 mm	4 mm	0,18 kg

Type	Port size	Air flow	Operating press.	Power Consumption	Weight
MNH 350 701	G 1/4"	1250 l/min	2 - 10 bar	3 W = / 5 VA ~	0,24 kg
MNH 351 701	G 1/4"	1250 l/min	2,5 - 10 bar	3 W = / 5 VA ~	0,24 kg



MNH 531 701/MNH 532 701/MNH 531 101 MNH 531 121/MNK 531 701

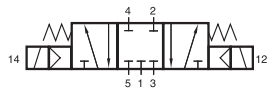

MNH 531 701
MNH 531 101
MNH 531 121
MNK 531 701
MNH 531 701 NPT
MNH 531 121 NPT

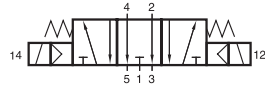

MNH 532 701

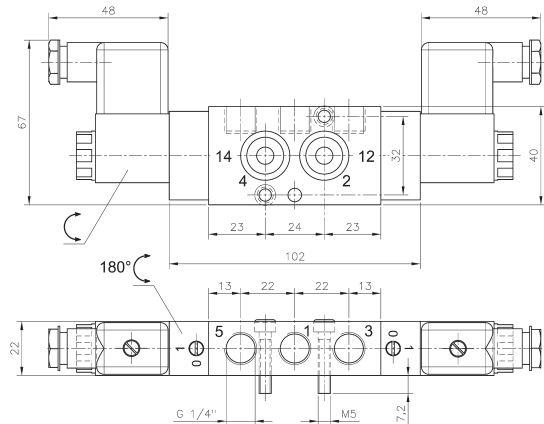
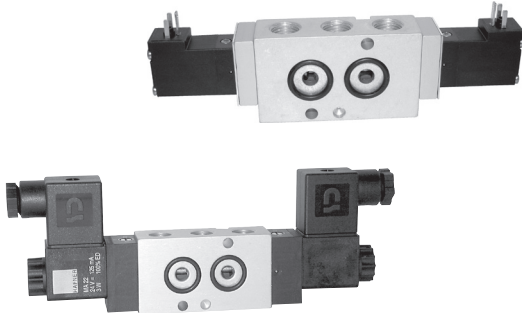

5/3-way solenoid valve with spring return to middle position. Interface according to Namur standard.

Type 531 centre closed
Type 532 centre exhausted
Other versions on request.

MNH generally with manual override to turn with actuators 230V/50Hz, 110V/50Hz, 24V/50Hz, 48V=, 24V=, 12V=.
Delivery includes 1 pin, 2 screws, 2 O-rings and 1 connector.

MNK with manual override to push with actuators 230V/50Hz, 110V/50Hz, 24V/50Hz, 24V=, 12V=, 6V=.
Delivery includes 1 pin, 2 screws and 2 O-rings.

Selected products displayed on this page are also available NPT threaded.

MNH 531 701/MNH 532 701/MNH 531 701 NPT

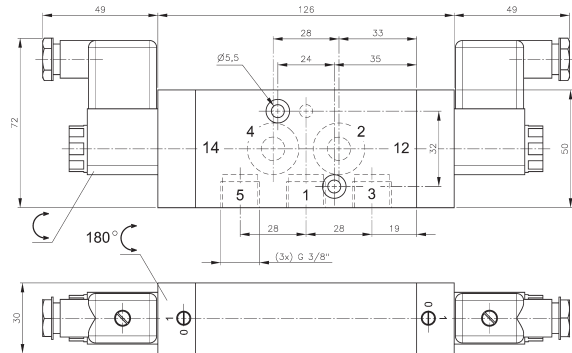

MNH 531 101

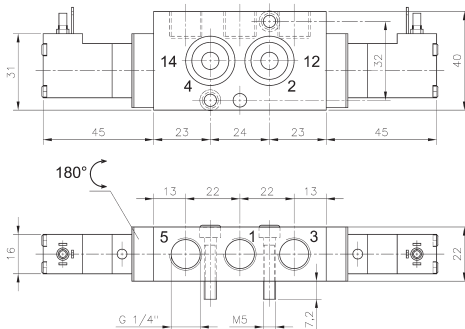
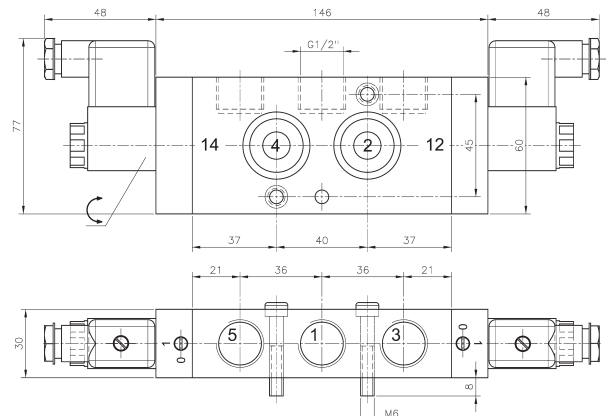

MNK 531 701

MNH 531 121/MNH 531 121 NPT

Type	Namur	Port size	Air flow	Operating press.	Power cons.	Weight
MNH 53_701	1/4"	G 1/4"	1250 l/min	3 - 10 bar	3 W = / 5 VA ~	0,36 kg
MNH 531 101	1/4"	G 3/8"	2250 l/min	1,5 - 10 bar	3 W = / 5 VA ~	0,84 kg
MNH 531 121	1/2"	G 1/2"	3000 l/min	1,0 - 10 bar	3 W = / 5 VA ~	0,87 kg
MNK 531 701	1/4"	G 1/4"	1250 l/min	3 - 10 bar	1,8 W = / 3 VA ~	0,32 kg
MNH 531 701 NPT	1/4"	1/4" NPT	1250 l/min	3 - 10 bar	3 W = / 5 VA ~	0,36 kg
MNH 531 121 NPT	1/2"	1/2" NPT	3000 l/min	1,0 - 10 bar	3 W = / 5 VA ~	0,87 kg

PN 310 701/PN 311 701/PN 310 121

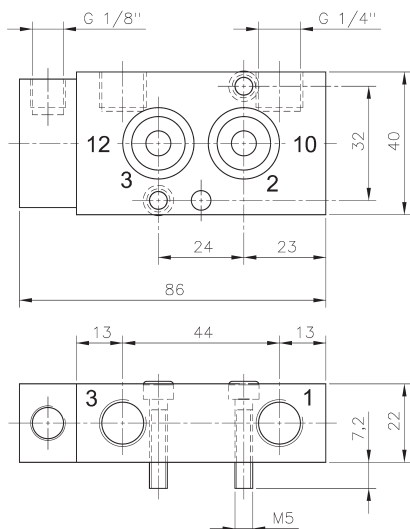

PN 310 701/PN 311 701

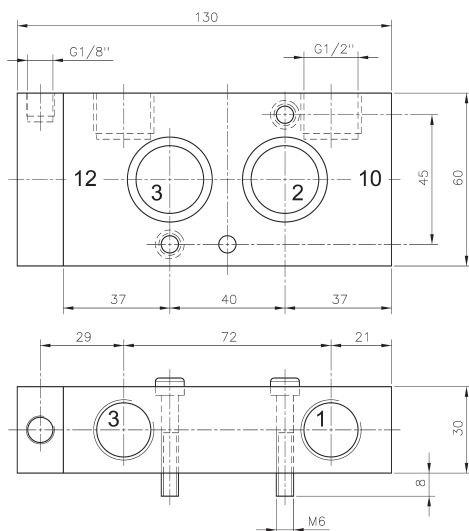

PN 310 121

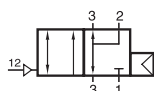

PN 310 701
PN 310 121

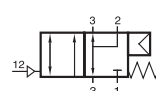

PN 311 701

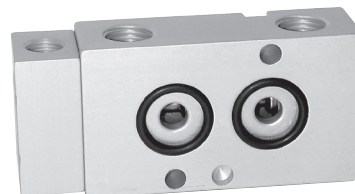

Pneumatically actuated 3/2-way spool valve. Interface according to Namur standard with exhaust recirculation („purge”).

PN 310 701 and PN 310 121 with pneumatic spring. For valves with pure pneumatic spring operating and actuation pressure should be at the same level. PN 311 701 with combined mechanical and pneumatic spring return.

Port sizes type 701: 1 and 3: G 1/4"
12: G 1/8"

Port sizes type 121: 1 and 3: G 1/2"
12: G 1/8"

Delivery includes 1 pin, 2 screws and 2 O-rings.

NPT threaded valves are available on request.

Type	Namur	Port size	Air flow	Operating press.	Actuation press.	Weight
PN 310 701	1/4"	G 1/4" - G 1/8"	1250 l/min	2 - 10 bar	the same	0,20 kg
PN 311 701	1/4"	G 1/4" - G 1/8"	1250 l/min	3 - 10 bar	3 - 10 bar	0,20 kg
PN 310 121	1/2"	G 1/2" - G 1/8"	3000 l/min	1 - 10 bar	the same	0,62 kg

PN 510 701/PN 511 701/PN 510 121 PN 520 701/PN 520 121

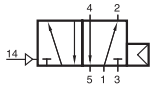

PN 510 701
PN 510 121

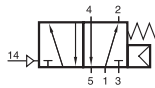

PN 511 701

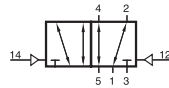

PN 520 701
PN 520 121



Pneumatically actuated 5/2-way spool valve. Interface according to Namur standard.

PN 510 701 and PN 510 121 with pneumatic spring. For valves with pure pneumatic spring operating and actuation pressure should be at the same level. PN 511 701 with combined mechanical and pneumatic spring return.

Port sizes type 701: 1, 3 and 5: G 1/4"
12 and 14: G 1/8"

Port sizes type 121: 1, 3 and 5: G 1/2"
12 and 14: G 1/8"

Delivery includes 1 pin, 2 screws and 2 O-rings.

NPT threaded valves are available on request.

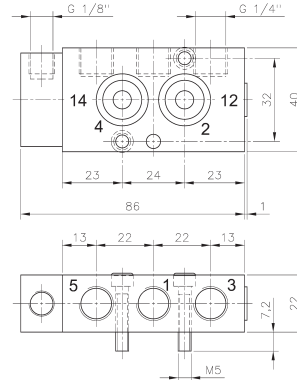

PN 510 701/PN 511 701

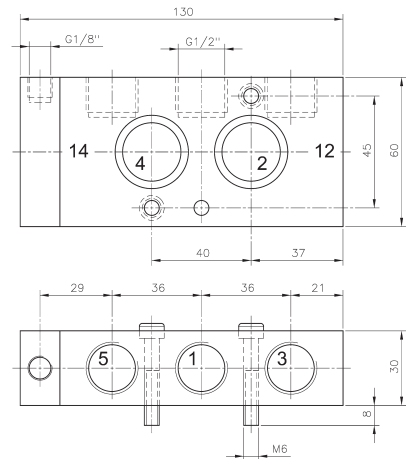

PN 510 121

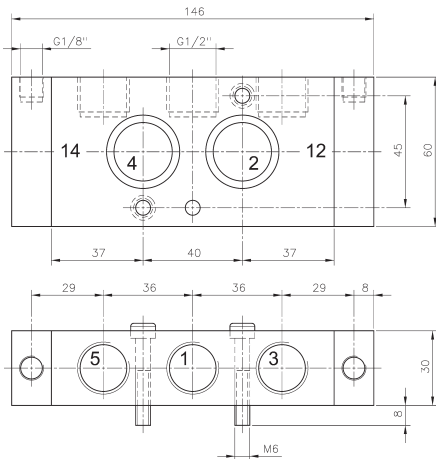

PN 520 121

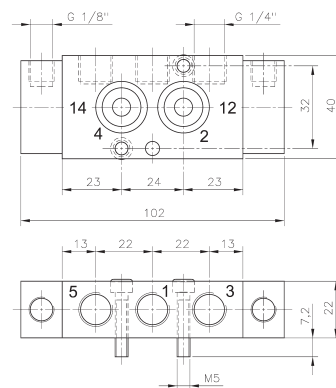

PN 520 701

Type	Namur	Port size	Air flow	Operating press.	Actuating press.	Weight
PN 510 701	1/4"	G 1/4" - G 1/8"	1250 l/min	1 - 10 bar	the same	0,19 kg
PN 511 701	1/4"	G 1/4" - G 1/8"	1250 l/min	3 - 10 bar	3 - 10 bar	0,19 kg
PN 510 121	1/2"	G 1/2" - G 1/8"	3000 l/min	1 - 10 bar	the same	0,60 kg
PN 520 701	1/4"	G 1/4" - G 1/8"	1250 l/min	1 - 10 bar	2,5 - 10 bar	0,22 kg
PN 520 121	1/2"	G 1/2" - G 1/8"	3000 l/min	1 - 10 bar	2,5 - 10 bar	0,67 kg

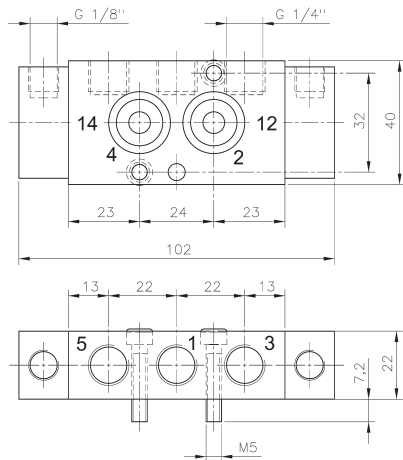
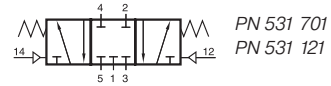

PN 531 701

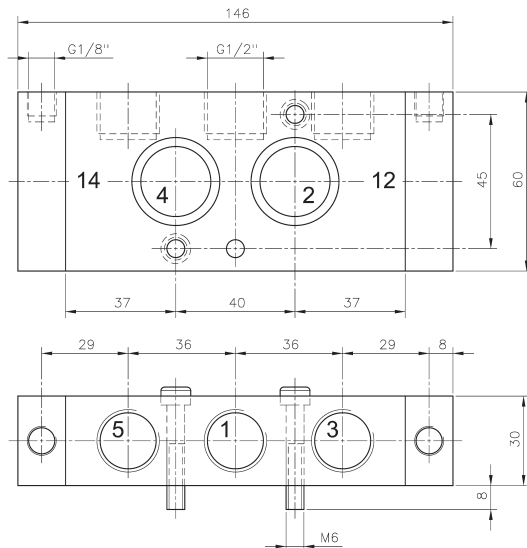

PN 531 121

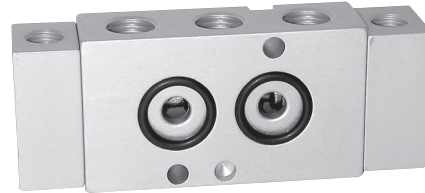

Pneumatically actuated 5/3-way spool valve with spring return to middle position, centre closed. Interface according to Namur standard.

Port sizes type 701: 1, 3 and 5: G 1/4"
12 and 14: G 1/8"

Port sizes type 121: 1, 3 and 5: G 1/2"
12 and 14: G 1/8"

Other 5/3-way versions (centre exhausted or pressurised) are available on request.

Delivery includes 1 pin, 2 screws and 2 O-rings.

NPT threaded valves are available on request.

Type	Namur	Port size	Air flow	Operating press.	Actuation press.	Weight
PN 531 701	1/4"	G 1/4" - G 1/8"	1250 l/min	1 - 10 bar	3 - 10 bar	0,22 kg
PN 531 121	1/2"	G 1/2" - G 1/8"	3000 l/min	1 - 10 bar	3 - 10 bar	0,67 kg

HVN 311 701/HVRN 320 701 HVN 511 701/HVRN 520 701

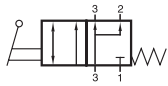

HVN 311 701

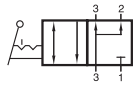

HVRN 320 701

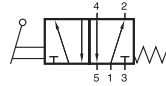

HVN 511 701

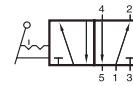

HVRN 520 701

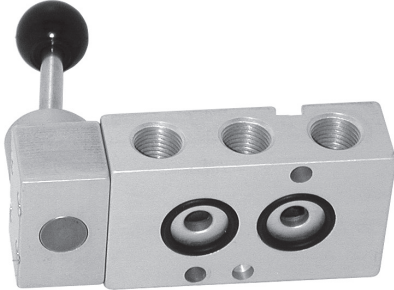

Lever actuated spool valves with 1/4" Namur interface. 4 versions are offered:

- HVN 311 701 3/2-way, normally closed with spring return
- HVRN 320 701 3/2-way, normally closed, indexed
- HVN 511 701 5/2-way with spring return
- HVRN 520 701 5/2-way indexed

3/2-way valves are normally closed and offer exhaust air recirculation („purge“).

The lever is sealed against the valve by using a metal ball.

Exhaust can be throttled.

Delivery includes 1 pin, 2 screws and 2 O-rings.

NPT threaded versions and 5/3-way valves are available on request.

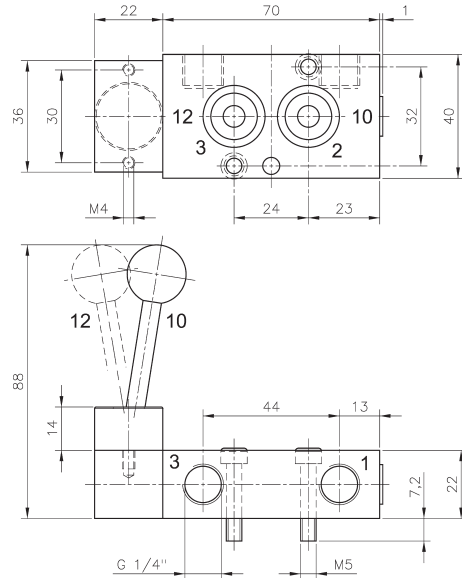

HVN 311 701/HVRN 320 701

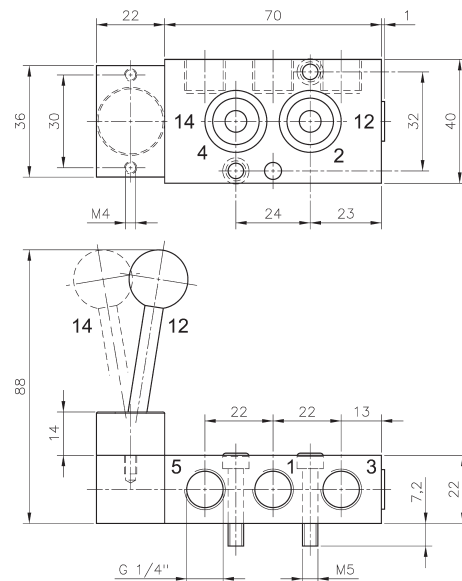

HVN 511 701/HVRN 520 701

Type	Function	Port size	Air flow	Operating press.	Actuating force	Weight
HVN 311 701	3/2-way spring	G 1/4"	1250 l/min	1 - 10 bar	20 N	0,24 kg
HVRN 320 701	3/2-way indexed	G 1/4"	1250 l/min	1 - 10 bar	20 N	0,24 kg
HVN 511 701	5/2-way spring	G 1/4"	1250 l/min	1 - 10 bar	20 N	0,24 kg
HVRN 520 701	5/2-way indexed	G 1/4"	1250 l/min	1 - 10 bar	20 N	0,24 kg

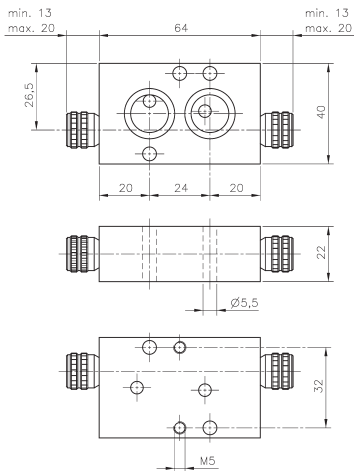
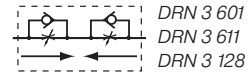

DRN 3 601

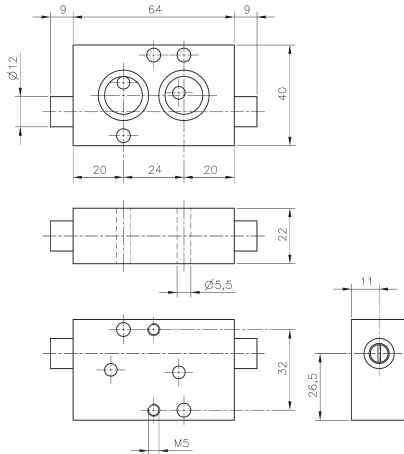

DRN 3 611

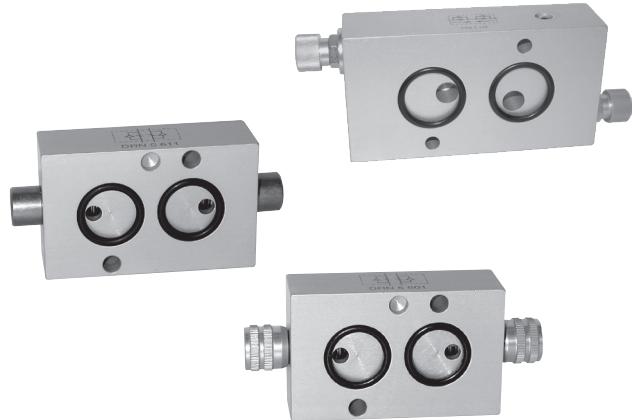

Block form flow regulator as intermediate plate, interface according to Namur standard, for 3/2-way valves with exhaust air recirculation.

To regulate the forward stroke of a single acting pneumatic actuator and to regulate the exhaust air going into the spring return unit. DRN 3 601 and DRN 3 128 to be operated manually, DRN 3 611 with a screw-driver.

Delivery includes 1 pin, 2 screws, 2 O-rings.

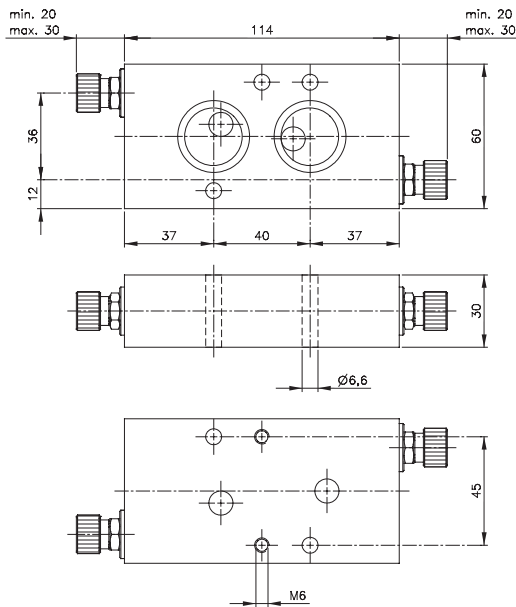

DRN 3 128

Type	Function	Namur	Port size	Max. air flow	Operating pressure	Weight
DRN 3 601	3-way	1/4"	Ø 5 mm	650 l/min	0,5 - 10 bar	0,18 kg
DRN 3 611	3-way	1/4"	Ø 5 mm	650 l/min	0,5 - 10 bar	0,18 kg
DRN 3 128	3-way	1/2"	Ø 8 mm	1.500 l/min	0,5 - 10 bar	0,60 kg



DRN 5 601/DRN 5 611/DRN 5 501

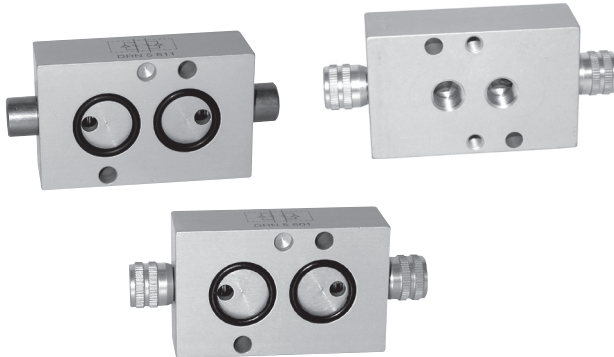
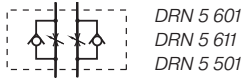

Block form flow regulator as intermediate plate, interface according to 1/4" Namur standard, for 5-way valves only.

To regulate the forward- and backward-stroke of a double acting pneumatic actuator. DRN 5 601 and DRN 5 501 to be operated manually, DRN 5 611 with a screw-driver. DRN 5 501 has 2 ports G 1/8" to be used when non Namurpilot-valve is in use.

Delivery includes 1 pin, 2 screws, 2 O-rings.

Delivery of DRN 5 501 includes additionally 2 longer screws for usage with Namurpilot-valve.

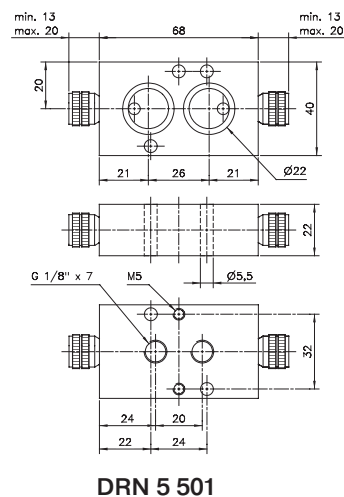
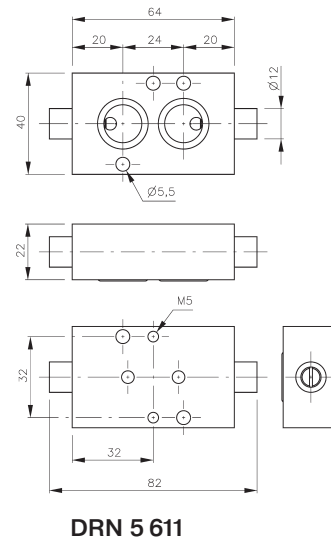
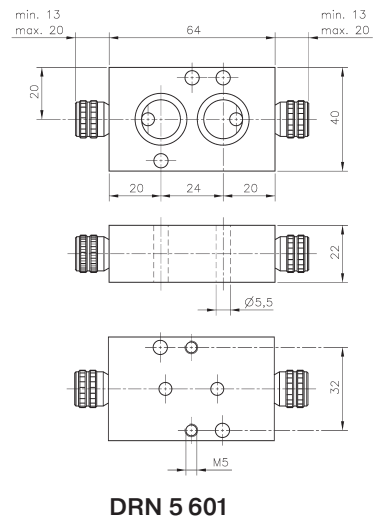

Type	Function	Port size	Max. air flow	Operating pressure	Weight
DRN 5 601	5-way	Ø 5 mm	650 l/min	0,5 - 10 bar	0,18 kg
DRN 5 611	5-way	Ø 5 mm	650 l/min	0,5 - 10 bar	0,18 kg
DRN 5 501	5-way	G 1/8"	650 l/min	0,5 - 10 bar	0,17 kg

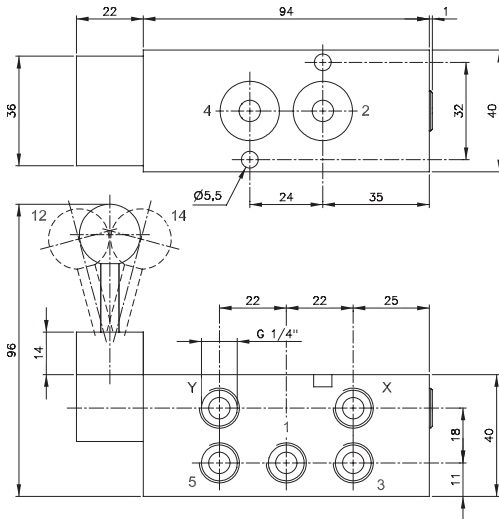
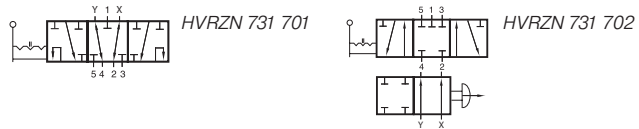

HVRZN 731 701

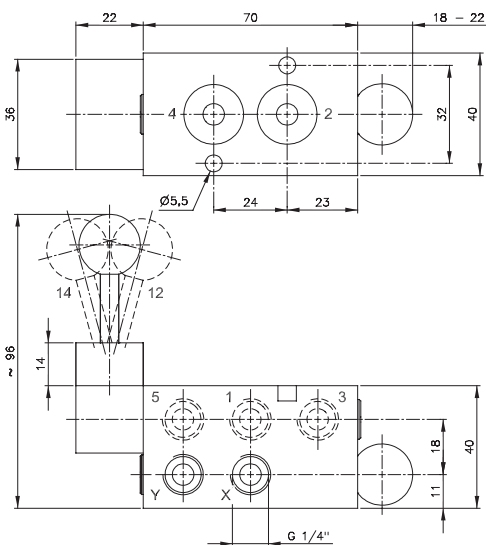

HVRZN 731 702

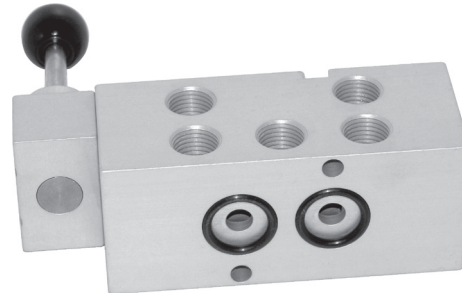

Lever valve for direct assemblage to an actuator with 1/4" Namur interface.

Valves offer the possibility to override a positioner.

Version 731 701:

Normally the lever is in the middle position and the actuator is piloted by the positioner. In this position the valve just feeds the signals from the positioner through to the actuator. In case of electric / electronic problems the actuator can be opened or closed manually.

Advantages of version 701 :

Only one lever to manipulate (no second actuation elements).

Overrides in manual mode the positioner, manual mode and automatic mode truly independent.

Version 731 702:

If the knob is pushed, air flows from the positioner from Y to 4 and from X to 2.

If the knob is pulled valve is in manual mode.

The lever valve is to be used as a centre closed 5/3-way valve, actuator can be fully opened, fully closed or put into intermediate position.

Advantage of version 702:

Offers in manual mode a centre closed 5/3-way-valve. Version 701 is in manual mode a 5/2-way-valve.

Safety lever:

In order to avoid unintended manual actuation the lever of both versions has to be pulled thoroughly for being manipulated out of central position.

Type	Function	Port size	Air flow	Operating press.	Actuating force	Weight
HVRZN 731 701	5/2-way indexed	G 1/4"	1250 l/min	1 - 10 bar	~ 25 N	0,53 kg
HVRZN 731 702	5/3-way indexed	G 1/4"	1250 l/min	1 - 10 bar	~ 25 N	0,45 kg

PN 411 701/P 411 121

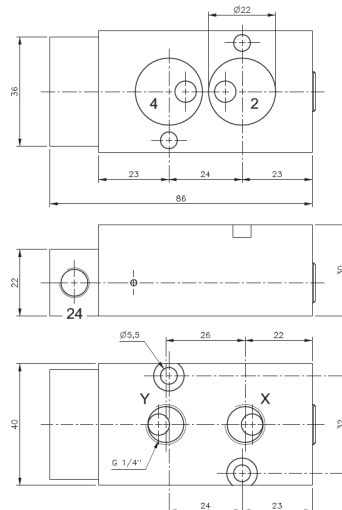
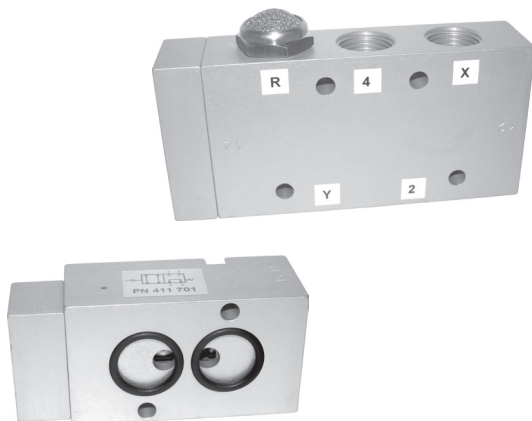
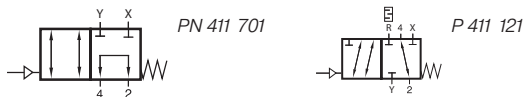

PN 411 701

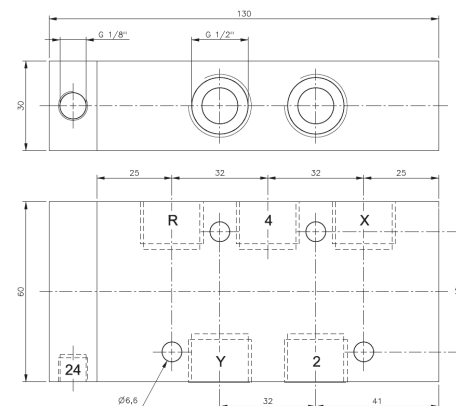

P 411 121

The **PN 411 701** is made for direct assemblage to an actuator with 1/4" Namurinterface. It offers a 1/4" Namurinterface towards the pilot-valve (use as sandwich plate) as well as ports G 1/4" for piped application.

The **P 411 121** is an in-line-version for high-flow-application, ported G 1/2".

Function:

As long as a pneumatic signal is applied, the valve forwards the signals applied to 2 and 4 through to X and Y. When no pneumatic signal is applied the ports 2 and 4 are shortcut.

Typical application:

On automated process-valve equipped with a gear-box for manual actuation in case of emergency. When failure occurs, compressed air might get trapped in the actuator. Manual operation might damage the actuator. Valve assures, that the user doesn't have to close the process valve against the force of the air.

Type	Port size	Air flow	Operating press.	Actuating press.	Weight
PN 411 701	G 1/4"	1250 l/min	1,5 - 10 bar	3 - 10 bar	0,20 kg
P 411 121	G 1/2"	3000 l/min	1 - 10 bar	3 - 10 bar	0,63 kg

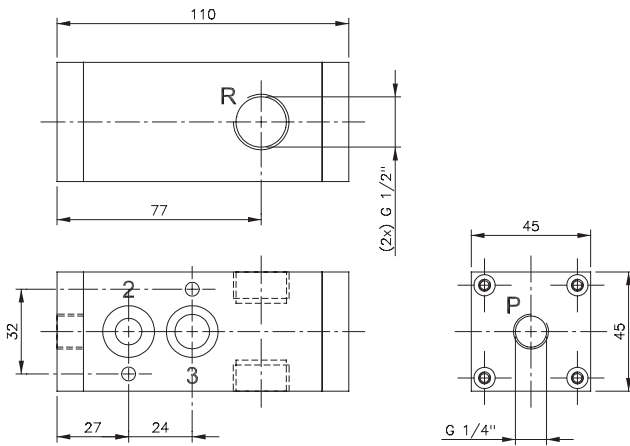
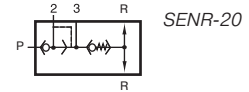

SENR-20



The valve is designed for fast closing of a spring-return actuator with 1/4" Namur-interface.

Any 3/2-way valve can be used as pilot valve. The interface towards the pilot valve is G 1/4". If requested the plate for the pilot-valve-interface can be exchanged, e.g. by a Namur-interface plate.

The block assures that only processed air that has been used to open the actuator is used in the spring-chamber (non-return-function). Excess air is released very fast by the quick-exhaust valve, exhaust-port G 1/2", orifice 10 mm. The non-return valve makes absolutely sure that no ambient atmosphere can be sucked into the actuator.

Two exhaust-ports R allow that the product can always be assembled so the silencer always faces downwards.

Low-temperature version available on request.

Type	Port size P	Port size R	Air flow P to 2	Air flow exhaust	Pressure-range	Weight
SENR 20	G 1/4"	G 1/2"	1250 l/min	2500 l/min	2 - 10 bar	0,54 kg

ZVP 701/ZVP 101/ZVP 121/ZVP 121-701

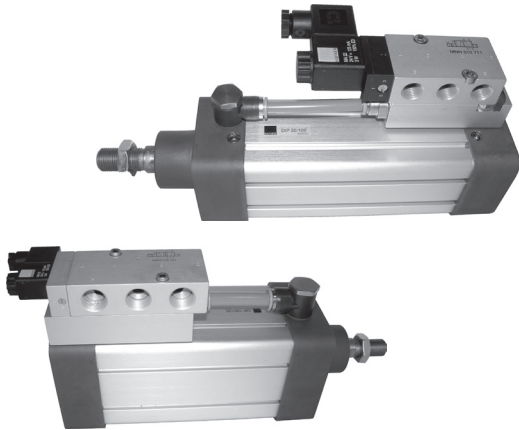

Plates to combine a Namur-valve with a double acting cylinder / the actuation-element of a knife-gate-valve.

ZVP 701 to be assembled onto a cylinder with G 1/4" ports (diameter 32, 40, 50 mm according to ISO 6431/ISO 15552). Designed for an orifice-size 7 mm in combination with e.g. MNH 510 711.

ZVP 101 to be assembled onto a cylinder with G 3/8" ports (diameter 63, 80 mm according to ISO 6431/ISO 15552). Designed for an orifice-size 10 mm in combination with e.g. MNH 510 101.

ZVP 121 to be assembled onto a cylinder with G 1/2" ports (diameter 100, 125 mm according to ISO 6431/ISO 15552). Designed for an orifice-size 12 mm in combination with e.g. MNH 510 121.

ZVP 121 - 701 to be assembled onto a cylinder with G 1/2" ports and equipped with a Namur-valve of 1/4" standard.

Plate can be equipped with different kinds of Namur-valves.

Delivery contains the plate and the banjo for one port.

Straight male fittings and rotating elbow fittings to make the other connection can be supplied on request.

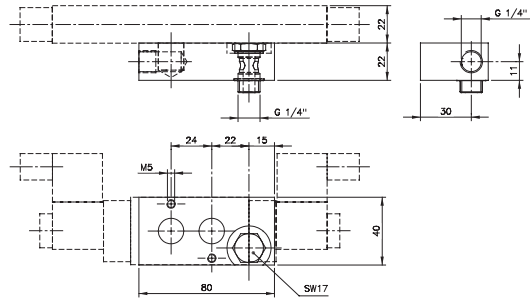

ZVP 701

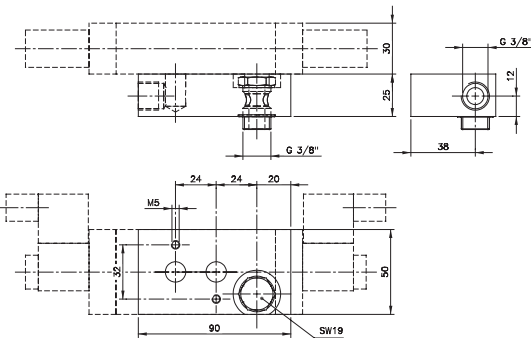

ZVP 101

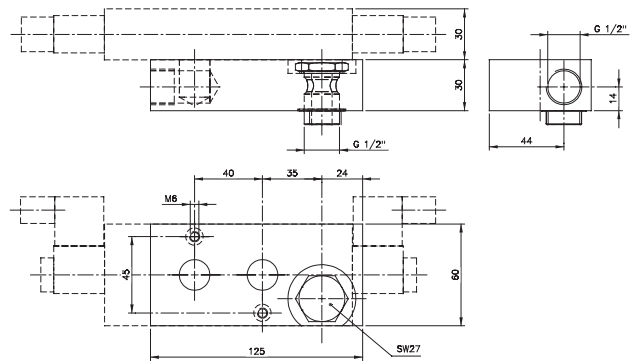

ZVP 121

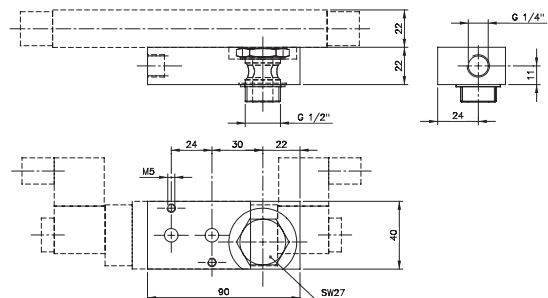

ZVP 121-701

Type	Port A	Port B	Namur	Orifice	Weight
ZVP 701	Banjo G 1/4"	G 1/4"	1/4"	7 mm	0,35 kg
ZVP 101	Banjo G 3/8"	G 3/8"	1/4"	10 mm	0,40 kg
ZVP 121	Banjo G 1/2"	G 1/2"	1/2"	12 mm	0,45 kg
ZVP 121-701	Banjo G 1/2"	G 1/4"	1/4"	7 mm	0,35 kg

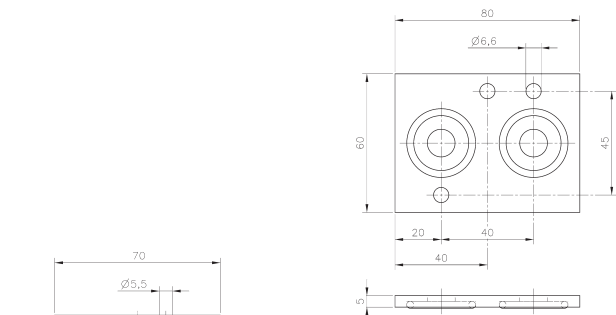

ZPN 6-5

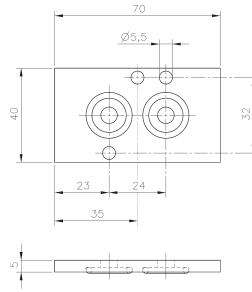

ZPN 5

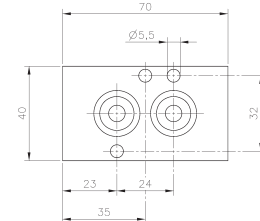

ZPN 8

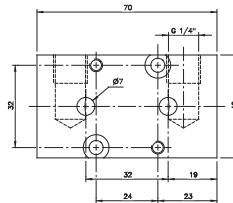

FPNW 22-1/4

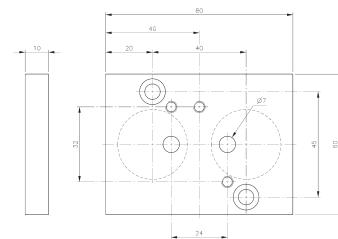

ZPN 6-10

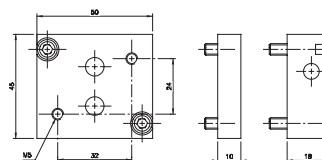

ZPN 701-90

Mounting accessories for Namur products when assembling them to an actuator.

O-ring seals are made from NBR 70° shore, fasteners such as screws and pins are made from stainless steel (A2) only.

FPNW 22-1/4:

Plate to convert a 5-way Namur-valve into an inline valve. The Namur ports 2 and 4 are transferred into the plate and offer G 1/4" BSP thread. Mounting plate can be assembled independently and the valve is attached later-on.

ZPN 6-10:

Adapter plate to be assembled onto an actuator with 1/2" interface. A 1/4" Namur-valve can be assembled to the plate. Saves money whenever the actuator does not have to be operated fast.

ZPN 701-90:

Plate to rotate a Namur-valve on the actuator by 90°. Orifice 7 mm assures full flow!

Type	Use and Content
ZPN 5A	Intermediate plate, made from anodised aluminum 5 mm thick to be used in case a 30 mm wide coil is to be assembled to a 22 mm wide 1/4" Namurvalve
ZPN 5K	Intermediate plate, made from Polyamid 5 mm thick to be used in case a 30 mm wide coil is to be assembled to a 22 mm wide 1/4" Namurvalve
ZPN 8	Intermediate plate, made from anodised aluminum 8 mm thick to be used in case a 36 mm wide coil is to be assembled to a 22 mm wide 1/4" Namurvalve
ZPN 6-5	Intermediate plate, made from anodised aluminum 5 mm thick to be used in case a 36 mm wide coil is to be assembled to a 30 mm wide 1/2" Namurvalve
FPNW 22-1/4	Plate to convert a Namurvalve into an inline valve
ZPN 6-10	Adapter-plate G 1/2" actuator to G 1/4" valve
ZPN 701-90	Plate to turn a Namurvalve by 90° on the actuator

Besides maximum flow of 1.250 NI/min at compact design there are 11 more competitive advantages of the Hafner Namurvalves series 701.

